

THE FUNDAMENTALS OF LIGHTING



HOLOPHANE[®]
LEADER IN LIGHTING SOLUTIONS

experience
lighting's
best.



PRISMATIC GLASS (LEFT)

ALUMINUM REFLECTOR (RIGHT)

INTRODUCTION

ILLUMINANCE IS LIGHT FALLING ON A SURFACE MEASURED IN FOOTCANDLES OR LUX. DISTRIBUTED WITH AN ECONOMIC AND VISUAL PLAN, IT BECOMES ENGINEERED LIGHTING AND, THEREFORE, PRACTICAL ILLUMINATION.

LIGHTING QUALITY

Achieving the required illuminance level does not necessarily ensure good lighting quality. The quality as well as the quantity of illuminance is important in producing a comfortable, productive, aesthetically pleasing lighted environment. The quality of the lighting system includes, but is not limited to, aspects of lighting such as proper color, good uniformity, proper room surface luminances, adequate brightness control and minimal glare.

Research has suggested that the lighting system can affect impressions of visual clarity, spaciousness and pleasantness. These feelings occur in spaces that are uniformly lighted with emphasis on higher luminances on room surfaces.

The improved user satisfaction from such spaces may or may not have any effect on worker performance. However, given two lighting systems with equal lifetime costs, lighting systems which provide improved worker satisfaction should be considered.

User satisfaction is often considered in the design of offices and commercial spaces, but ignored in industrial spaces. However, the industrial environment should be designed to provide a high-quality visual environment, yielding improved worker satisfaction and possibly improved productivity as well. This can be accomplished by using lighting systems which produce the proper luminance on ceilings and walls.

The photo on the left illustrates two lighting systems in the same industrial environment. Both lighting systems provide the same quantity of horizontal illuminance on the work plane. The system on the right provides little upright, resulting in the typical “cavern” effect associated with industrial spaces. The system on the left provides upright and improves the luminance of the ceiling and vertical surfaces. This system can provide workers with a feeling of increased spaciousness. The upright component also tends to improve work plane illuminance uniformity, reducing shadows and possibly yielding improved feelings of visual clarity.

Any lighting design should consider the impressions of the user of the space. The photograph on the left indicates that even an industrial environment can be improved with the hope of providing better working conditions and improved satisfaction and productivity for the worker.

A lighting designer has four major objectives:

1. Provide the visibility required based on the task to be performed and the economic objectives.
2. Furnish high quality lighting by providing a uniform illuminance level, where required, and by minimizing the negative effects of direct and reflected glare.
3. Choose luminaires aesthetically complimentary to the installation with mechanical, electrical and maintenance characteristics designed to minimize operational expense.
4. Choose sustainable products that minimize energy usage while achieving the visibility, quality and aesthetic objectives.

There are two parts to the solution of a design problem:

1. To select luminaires which are designed to control the light in an effective and energy efficient manner.
2. To apply them to the project with all the skill and ingenuity the designer can bring to bear from his or her own knowledge and all the reliable sources available.

TABLE OF CONTENTS

Introduction	2-3
Lighting Basics	4-5
Light Sources and Lamp Characteristics	6-7
Photometry	8-9
Holophane Research and Development	10-13
The Light and Vision Center	14-15
Visual Professional Edition	16-17
Holophane.com Resources	18-19
Summary	19



LIGHTING BASICS

AN UNDERSTANDING OF SOME OF THE FUNDAMENTAL TERMS IN LIGHTING TECHNOLOGY IS BASIC TO GOOD DESIGN PRACTICE. THE MORE IMPORTANT TERMS AND CONCEPTS ARE REVIEWED HERE FOR THIS PURPOSE.

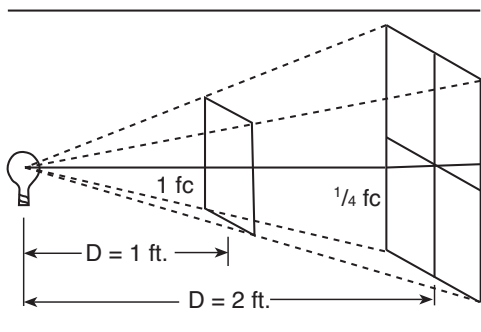

Figure 1

LUMINOUS FLUX

Luminous flux is the time rate of flow of light as measured in lumens. It is a measure of the total light emitted by a source and is most commonly used for measurement of total lamp output.

LUMINOUS INTENSITY (I)

The candela is the unit of intensity (I) and is analogous to pressure in a hydraulic system. It is sometimes called "candlepower" and describes the amount of light (lumens) in a unit of solid angle. This unit of solid angle is called the steradian. It will be seen from Figure 1 that as the light travels away from the source the solid angle covers a larger and larger area; but the angle itself remains the same, as does the amount of light it contains. Intensity therefore, in a given direction is constant regardless of distance. **See Figure 1**

$$I = \frac{(\text{lumens})}{(\text{steradians})}$$

ILLUMINANCE (E)

Illuminance is the quantity of light reaching a unit area of surface and is measured in footcandles or lux. As the area covered by a given solid angle becomes larger with distance from the source, the included light flux remains the same. The illumination density of light on the surface decreases, therefore, with the square of the distance. Illuminance is defined by the intensity (I) in candelas directed toward point P, divided by the square of the distance (D) from the source to the surface.

$$E = \frac{I}{D^2}$$

This formula holds only if the receiving surface is perpendicular to the source direction. If light is incident at some other angle, **See Figure 2**, the formula becomes:

$$E = \frac{I \cos \theta}{D^2}$$

- where E = illuminance in footcandles (fc) or lux
- I = intensity in candelas (cd) toward point P
- D = distance in feet or meters
- θ = angle of incidence

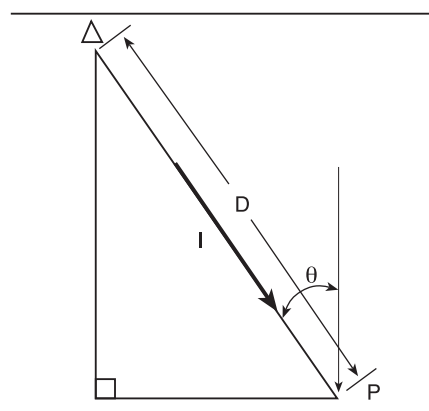

Figure 2

LUMINANCE (L)

Luminance, defined as intensity in a given direction divided by a surface's projected area as seen by the observer. "Brightness" is a subjective sensation of luminance varying from very dim to very bright. Objectively it is referred to as luminance. The surface may be a luminaire surface or a reflecting surface, such as a wall or roadway.

The direct luminance of luminaires at various angles of view is a major factor in the visual comfort evaluation of an installation using those luminaires. In general, it is desirable to minimize the brightness of ceiling mounted luminaires at the high vertical angles, 60°-90°. When the intensity is in candelas, and the projected area is in meters, the unit of luminance is candelas per square meter (cd/m²).

EXITANCE (M)

It is often desirable to calculate the amount of light reflected from room surfaces. The total amount of light reflected, regardless of direction, is Exitance. Exitance = illuminance x reflection factor

$$M = E \times \rho$$

- Where E = Illuminance in footcandles
- ρ = the reflection factor of the surface expressed as the percentage of light reflected
- M = the resulting exitance in lumens per sq. foot

METRIC SYSTEM

As the U.S.A. moves toward conversion to the metric system to conform with the scientific fields and the rest of the world, our illumination engineering will convert to the International System of Units (SI). Only the terms involving length or area, illuminance and luminance, are affected. Illuminance (E) is stated in lux (lumens per sq. meter) in the metric system. 1fc = 10.76 lux. Luminance (L) is stated in candelas per sq. meter in the metric system.



LIGHT SOURCES AND LAMP CHARACTERISTICS

ONE OF THE FIRST DECISIONS IN THE DESIGN OF A GOOD LIGHTING SYSTEM IS THE CHOICE OF A LIGHT SOURCE. A NUMBER OF LIGHT SOURCES ARE AVAILABLE, EACH WITH ITS OWN UNIQUE COMBINATION OF OPERATING CHARACTERISTICS. A FEW OF THE LAMP CHARACTERISTICS THAT A LIGHTING DESIGNER SHOULD CONSIDER WHEN CHOOSING A LIGHT SOURCE INCLUDE EFFICACY, OR LUMENS PER WATT; COLOR; LAMP LIFE; AND LAMP LUMEN DEPRECIATION, OR THE PERCENT OF OUTPUT THAT A LAMP LOSES OVER ITS LIFE.

Although there are hundreds of lamps on the market today, they can be categorized by construction and operating characteristics into three main groups: fluorescent, LED and high intensity discharge (HID). HID lamps can be grouped into these major classes: high pressure sodium and metal halide. Another type of lamp, low pressure sodium (LPS), shares some characteristics of HID lamps. Induction lamps are a special type of fluorescent.

FLUORESCENT

The fluorescent lamp produces light by activating selected phosphors on the inner surface of the bulb with ultraviolet energy, which is generated by a mercury arc. Because of the characteristics of a gaseous arc, a ballast is needed to start and operate fluorescent lamps.

The advantages of the fluorescent light source include improved efficacy and longer life than incandescent lamps. Efficacies for fluorescent lamps range anywhere from 50 to 100 lumens per watt. Their low surface brightness and heat generation make them ideal for offices and schools where thermal and visual comfort are important.

The disadvantages of fluorescent lamps include their large size for the amount of light produced. This makes light control more difficult, which results in a diffuse, shadowless environment. Their use in outdoor areas becomes less economical because light output of a fluorescent source is reduced at low ambient temperatures.

INDUCTION

Induction lamps are electrodeless fluorescent lamps driven by high-frequency current, typically between 250kHz and 2.65MHz, usually via an external generator. They are available in limited wattages and are known for exceptionally long service life: up to 100,000 hours. Lamp efficacies typically range from 64 to 88 lumens per watt. Color rendition with induction lamps is very good. Although not easily optically controllable in a luminaire because of the large lamp size, induction lighting is often employed in applications where luminaires may be very difficult to access or where maintenance costs are a strong factor in the lighting design and installation. Initial system purchasing costs are high compared to the best HID or fluorescent systems.

LED

Light Emitting Diode (LED) sources are made from semiconductor material that emits light when energized. Heat management is one of the main concerns for LED luminaires. Proper heat management will allow for long LED life at or above 50,000 hours and is necessary to maintain proper light output. The efficacies for LEDs luminaires are as good as fluorescent and HID sources and are continuing to be improved. The more efficacious LEDs look whiter with typically high CCT (correlated color temperature) in the range of 5000 to 8000 degrees Kelvin. Warmer color temperatures are available but their efficacy will be reduced. LEDs provide instant on/off capability and can be dimmed.

HIGH INTENSITY DISCHARGE (HID)

High intensity discharge sources include mercury vapor, metal halide, and high pressure sodium (HPS) lamps. Light is produced in HID and low pressure sodium (LPS) sources through a gaseous arc discharge using a variety of elements. Each HID lamp consists of an arc tube which contains certain elements or mixtures of elements which, when an arc is created between the electrodes at each end, gasify and generate visible radiation.

The major advantages of HID sources are their high efficacy in lumens per watt, long lamp life and point-source characteristic for good light control. Disadvantages include the need for a ballast to regulate lamp current and voltage as well as a starting aid for HPS and some MH and the delay in restriking after a momentary power interruption.

● High Pressure Sodium (HPS)

In the 1970s, as increasing energy costs placed more emphasis on the efficiency of lighting, high pressure sodium lamps (developed in the 1960s) gained widespread usage. With efficacies ranging from 80 to 140 lumens per watt, these lamps provide about 7 times as much light per watt as incandescent and about twice as much as some mercury or fluorescent. The efficacy of this source is not its only advantage. An HPS lamp also offers the longest life (24,000+ hrs.) and the best lumen maintenance characteristics of all HID sources.

The major objection to the use of HPS is its yellowish color and low color rendition. It is ideal mainly for some warehouse and outdoor applications.

● Metal Halide (MH)

Metal halide lamps are similar in construction to mercury lamps with the addition of various other metallic elements in the arc tube. The major benefits of this change are an increase in efficacy to 60 to 100 lumens per watt and an improvement in color rendition to the degree that this source is suitable for commercial areas. Light control of a metal halide lamp is also more precise than that of a deluxe mercury lamp since light emanates from the small arc tube, not the total outer bulb of the coated lamp.

Pulse-start metal halide lamps have several advantages over standard (probe-start) metal halide: higher efficacy (110 lumens per watt), longer life, and better lumen maintenance.

A disadvantage of the metal halide lamp is its shorter life (7,500 to 20,000 hrs) as compared to induction, LEDs and high pressure sodium. Starting time of the metal halide lamp is approximately 4-7 minutes depending on the ambient temperatures. Restriking after a voltage dip has extinguished the lamp, however, can take substantially longer, depending on the time required for the lamp to cool.

● Low Pressure Sodium (LPS)

Low pressure sodium offers the highest initial efficacy of all lamps on the market today, ranging from 100 to 180 lumens per watt. However, because all of the LPS output is in the yellow portion of the visible spectrum, it produces extremely poor and unattractive color rendition. Control of this source is more difficult than with HID sources because of the large size of the arc tube. The average life of low pressure sodium lamps is 18,000 hours. While lumen maintenance through life is good with LPS, there is an offsetting increase in lamp watts, reducing the efficacy of this lamp type with use.



PHOTOMETRY

“PHOTOMETRY” MEANS “THE MEASUREMENT OF LIGHT.” THE TERM “PHOTOMETRY” IS OFTEN USED TO DEFINE ANY TEST DATA WHICH DESCRIBES THE CHARACTERISTICS OF A LUMINAIRE’S LIGHT OUTPUT. THE MOST COMMON TYPE OF PHOTOMETRIC DATA INCLUDES CANDLEPOWER DISTRIBUTION CURVES, SPACING CRITERIA, LUMINAIRE EFFICIENCY, ISOFOOTCANDLE PLOTS, COEFFICIENTS OF UTILIZATION AND LUMINANCE DATA. PHOTOMETRIC DATA IS PLACED INTO STANDARD FORMAT (IESNA FILE) FOR USE IN LIGHTING CALCULATION COMPUTER PROGRAMS.

The purpose of a photometric report is to accurately describe the performance of a luminaire, to enable the designer to select the lighting equipment and design a fixture layout which best meets the needs of the job.

Following is a review of the more frequently used types of photometric data.

CANDLEPOWER DISTRIBUTION CURVE

The photometric distribution curve is one of the lighting designer's most valuable tools. It is a cross-sectional "map" of intensity (candelas) measured at many different vertical angles. It is a two-dimensional representation and therefore shows data for one plane only. If the distribution of the unit is symmetric, the curve in one plane is sufficient for all calculations. If asymmetric, such as with street lighting and fluorescent units, three or more planes are required. In general, incandescent and HID reflector units are described by a single vertical plane of photometry. Fluorescent luminaires require a minimum of one plane along the lamp axis, one across the lamp axis and one at a 45° angle. The greater the departure from symmetry, the more planes needed for accurate calculations.

COEFFICIENT OF UTILIZATION

A coefficient of utilization refers to the ratio of lumens which ultimately reach the work plane to the total lumens generated by the lamp. CU values are necessary for hand calculating average illuminance levels and are provided in one of two ways: a CU table or a CU curve. A CU curve is usually provided for units intended for outdoor use or units with a distribution radically asymmetric. A CU table is provided for units which are used primarily indoors.

ISOFOOTCANDLE PLOT

Isofootcandle plots are used to describe the light pattern produced by a luminaire, generally for outdoor luminaires. These plots are derived from the candlepower data and show exact plots or lines of equal footcandle levels on the work plane when the fixture is at a designated mounting height.

SPACING CRITERIA

Spacing criteria provide the designer with information regarding how far apart luminaires may be spaced while maintaining acceptable illumination uniformity on the work plane. Criteria for spacing are generally conservative; they take into account the direct component of illumination only and ignore the indirect component of light, which can contribute significantly to the uniformity. However, used within its limits, a Spacing Criterion can be valuable. To use the Spacing Criterion, multiply the net mounting height (luminaire to work plane) by the Spacing Criterion number.

IES FILES

Photometric data is available on the holophane.com web site in a standard format. These "IES files" are used by lighting computer programs like Visual to perform lighting calculations.

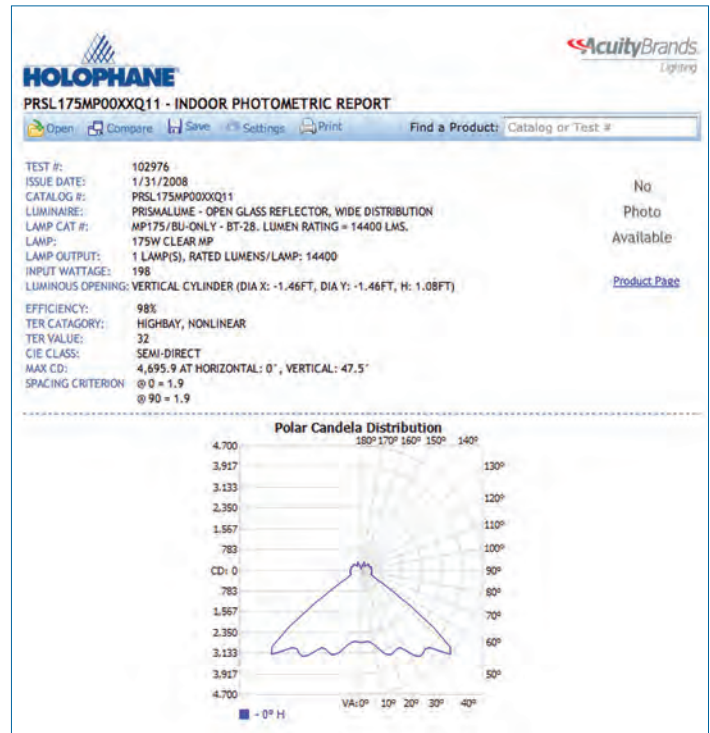

COEFFICIENTS OF UTILIZATION - ZONAL CAVITY METHOD

RCC %:	80				70				50				30			
RW %:	70	50	30	0	70	50	30	0	50	30	20	50	30	20		
RCR: 0	1.13	1.13	1.13	1.13	1.09	1.09	1.09	.84	1.01	1.01	1.01	.94	.94	.94		
1	1.04	.99	.95	.91	1.00	.96	.92	.71	.89	.86	.83	.83	.80	.78		
2	.95	.87	.81	.75	.91	.84	.78	.61	.78	.74	.70	.73	.69	.66		
3	.87	.77	.69	.63	.83	.74	.67	.52	.62	.64	.59	.65	.60	.56		
4	.79	.68	.60	.53	.76	.66	.58	.45	.52	.55	.50	.58	.52	.48		
5	.73	.60	.52	.46	.70	.59	.51	.39	.45	.48	.43	.51	.46	.41		
6	.67	.54	.46	.39	.64	.52	.44	.34	.41	.42	.37	.46	.40	.36		
7	.62	.49	.40	.34	.59	.47	.39	.30	.44	.37	.32	.42	.36	.31		
8	.57	.44	.36	.30	.55	.43	.35	.26	.40	.33	.29	.38	.32	.28		
9	.53	.40	.32	.27	.51	.39	.31	.23	.37	.30	.25	.35	.29	.24		
10	.49	.36	.29	.24	.47	.35	.28	.21	.34	.27	.23	.32	.26	.22		

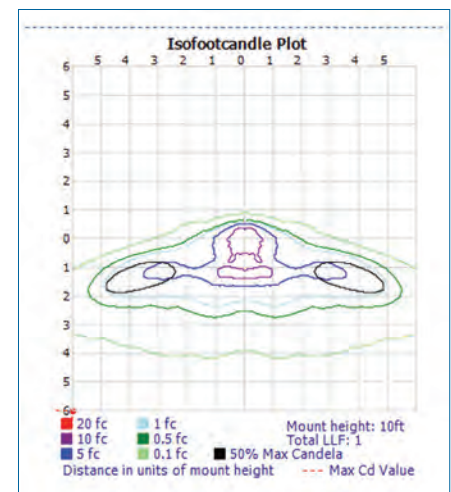



RESEARCH AND DEVELOPMENT

THE HIGH-CALIBER PERFORMANCE CHARACTERISTIC OF HOLOPHANE LUMINAIRES IS A RESULT OF QUALITY IN CONCEPT, RESEARCH, DEVELOPMENT AND EXECUTION. THIS DEPENDS ON A STAFF WITH ABILITY AND INTEGRITY, ALONG WITH THE PHYSICAL PLANT AND EQUIPMENT TO CARRY ON THEIR WORK. THE FOLLOWING ARE SOME BRIEF ASPECTS OF THE MORE IMPORTANT ACTIVITIES AND FACILITIES VITAL TO THE CREATION OF QUALITY HOLOPHANE LIGHTING PRODUCTS.

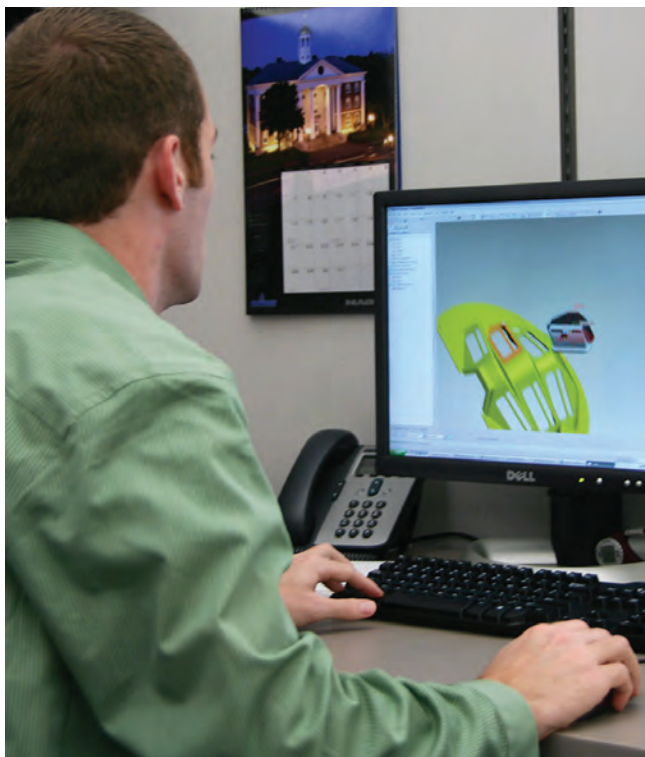

CAD SYSTEM

A Computer Aided Design system is used for the precise design of optical and fixture components to assure precise light control and manufacturing tolerances from all the elements that make up the luminaire assembly.



MODEL SHOP

A complete wood and metal working shop for the preparation of models and working prototypes of luminaires under design.

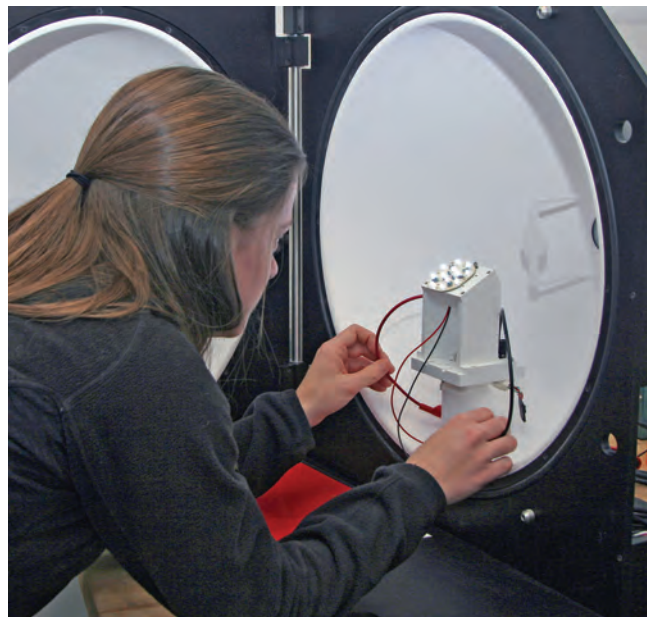

OPTICAL DESIGN

A visual evaluation facility to aid in the optical design of high quality light control elements of Holophane luminaires.



ELECTRONICS AND ELECTRICAL LABS

State of the art electronics and electrical labs fully equipped to simulate the applications and electrical stresses found in the field. Electronic and magnetic ballasts are designed and validated to meet ANSI, UL, FCC and our internal quality specifications. Properly designed and validated ballasts insure our customers get the optimal luminaire performance and ballast life Holophane products are known to deliver.

RESEARCH AND DEVELOPMENT



PHOTOMETRIC LAB

The Holophane Photometry Lab follows standards set by the Illuminating Engineering Society of North America.

The lab has two single-cell spinning mirror photometers with the capability of measuring the light distribution every 1°. Each luminaire that is tested is rotated to measure up to 72 planes of data. The systems are fully automated; the photocell readings are sent directly to an in-house computer which generates Photometric Test Reports used for calculation and analysis. Photometric reports are available in IESNA format on our Web site for use in Visual and other lighting application programs.



THERMAL LAB

Heat testing facility where luminaires and components are subjected to heat conditions well in excess of their normally expected exposure under field use. While this laboratory is used for research and development of luminaires, a significant part of its activities is directed to the meeting and maintenance of Underwriters' Laboratories requirements.

Holophane's Electric and Thermal Labs are UL certified and are audited annually for compliance.



WATER SPRAY LAB

Resistance to water penetration is evaluated in this closed cycle water spray system. Luminaires can be tested for standard UL wet-location and outdoor marine suitability. Also, a special 100-gallon per minute, 100-psi spray can be used to test such severe conditions as those found in tunnels. IP (Ingress Protection) testing for both water and dust are conducted on luminaires.



VIBRATION LAB

Stability of equipment under a variety of vibration loadings is rigorously tested to meet specifications and field-use conditions. This assures product reliability when luminaires and poles are subjected to various wind conditions.



LIGHTING DESIGN

A department staffed with professional lighting designers and engineers, to aid consultants and users in reaching their lighting decisions. The department uses various lighting analysis programs for their lighting designs.



MATERIALS LAB

A facility for the testing of materials for strength, corrosion resistance and other properties related to luminaires.



INDOOR AND OUTDOOR LIGHTING

The indoor and outdoor lighting demonstration labs feature complete luminaire systems for visual evaluation of a variety of lighting systems.



LIGHT AND VISION CENTER

LIGHTING EDUCATION IS A KEY TO UNDERSTANDING GOOD QUALITY LIGHTING. THE HOLOPHANE LIGHT AND VISION CENTER OFFERS A SERIES OF SEMINARS GEARED TOWARD LEARNING AND EXPERIENCING LIGHTING. DEPENDING ON THE SEMINAR EMPHASIS, LEARN ABOUT INDUSTRIAL, SECURITY, COMPUTER CALCULATIONS, ROADWAY, STREET OR TUNNEL LIGHTING. SEE AND TOUCH HIGH PERFORMING AND EASY TO MAINTAIN PRODUCTS. ENJOY THE SITES, SOUNDS AND GOOD FOOD OF THE QUANT, NEW ENGLAND-STYLE VILLAGE OF GRANVILLE, OHIO.

Light & Vision Center

TYPICAL SEMINAR HIGHLIGHTS

- Fundamentals in Lighting, Optics, Photometrics
- Lighting Design Techniques
- Recommended Practices
- Recent Research Findings
- Holophane Products
- American Electric Lighting Products
- New Technologies like LEDs and Induction Lamps

SEMINAR FOCUS

Each seminar focuses on a specific area of lighting:

- Advanced Roadway Lighting Seminar
- Computer Lighting Calculations for Interior Applications
- Computer Lighting Calculations for Exterior Applications
- Distributor Seminar
- Industrial Lighting Seminar
- Security Lighting for Crime Deterrence Seminar
- Sustainable Lighting Seminar
- Utility Outdoor Lighting Seminar

SEMINAR LOCATION

Most seminars are held in Granville, Ohio. Attendees will stay at the historic Granville Inn at 314 E. Broadway Street in beautiful Granville, Ohio. Holophane provides hotel, meals, and transportation from and to Columbus, Ohio airport. The Holophane L&V is located at 3825 Columbus Road, Bldg. A, Granville, OH 43230.

DAY 1: Seminar begins at 6:00 PM with a welcome dinner.

DAY 2: Seminar starts at 8 and ends at 5 with dinner following.

DAY 3: Seminar begins at 8 and ends at 3:30 PM.

REGISTRATION

For more information about seminars contact your local Holophane sales representative or visit www.holophane.com. Online registration is required. Once registered, you will receive a confirmation email, confirmation number and have access to the registration web site.

CONTINUING EDUCATION

Seminars are AIA Registered. The generic portion of the seminar provides Continuing Education Hours for Architects (LU), Lighting Certified (LEU), or Professional Engineers (PDH).



The screenshot shows the registration page for a seminar. At the top, it says "LIGHTING EDUCATION SEMINARS". Below that is the "Light & Vision Center" logo and address: "3825 Columbus Road, SW Bldg A, Granville, Ohio 43230". The main heading is "Computer Lighting Calculation Seminar: Interior". The page includes a "Summary" section with a description of the seminar, a "When" section with dates "Monday, May 17, 2010 8:00 PM - Wednesday, May 19, 2010 3:30 PM Eastern Time Zone", and a "Where" section with the address and phone number "740-3494298, 740-8777497 ext.". There are also buttons for "Add to Calendar", "Get Location Map", and "Get Driving Directions". At the bottom, it lists the "Planner" as "Greg Subisak, PE, LC" and the "Capacity" as "20 (15 remaining)".

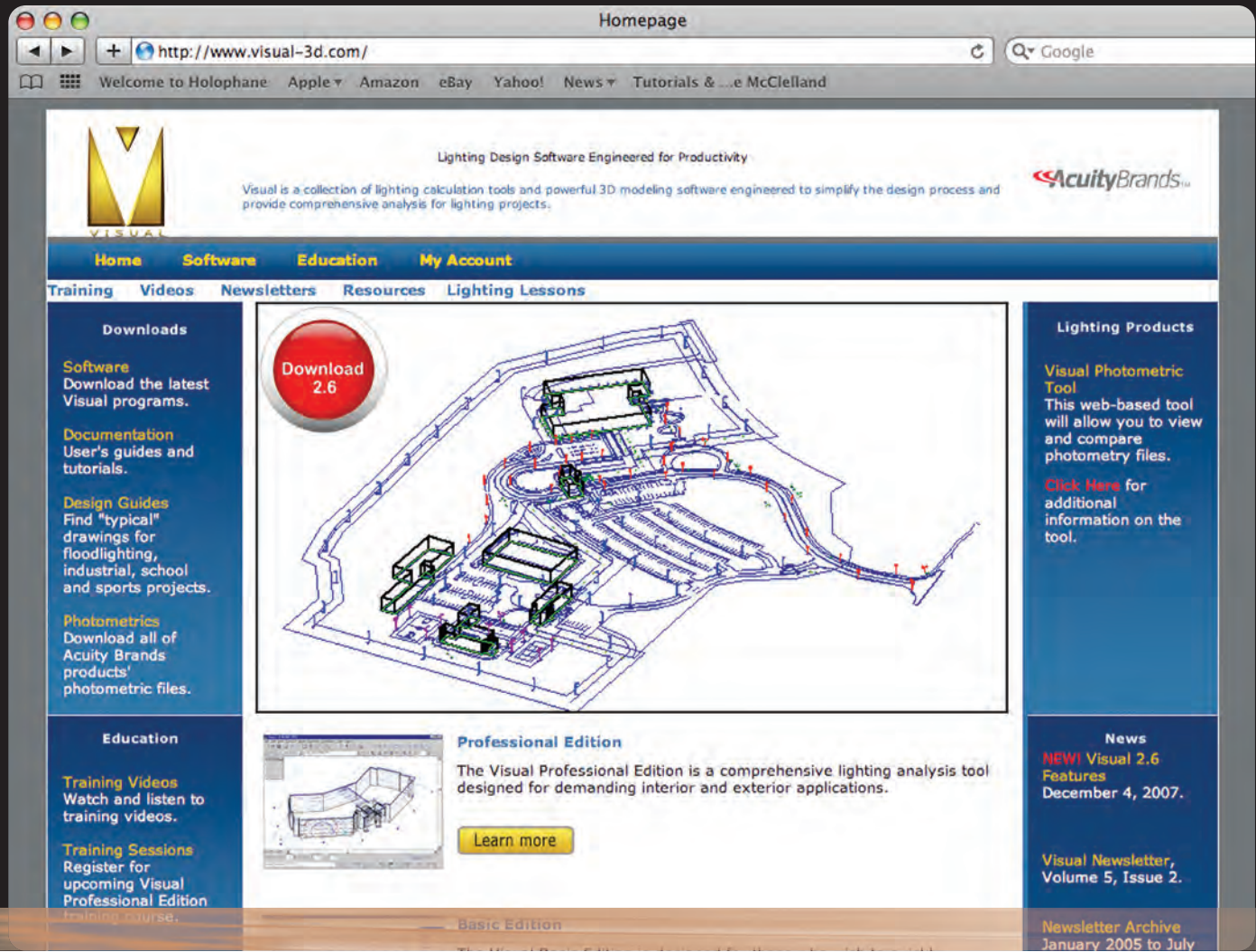

VISUAL

THE PROFESSIONAL EDITION OF VISUAL IS A COLLECTION OF LIGHTING CALCULATION TOOLS DESIGNED FOR MORE DEMANDING INTERIOR AND EXTERIOR APPLICATIONS. THE PROFESSIONAL EDITION PROVIDES THE ABILITY TO MODEL COMPLEX ARCHITECTURE, INCLUDING SLOPED OR ANGLED SURFACES, DOMES, BARREL VAULTS, AND OBSTRUCTIONS.



<http://www.visual-3d.com>

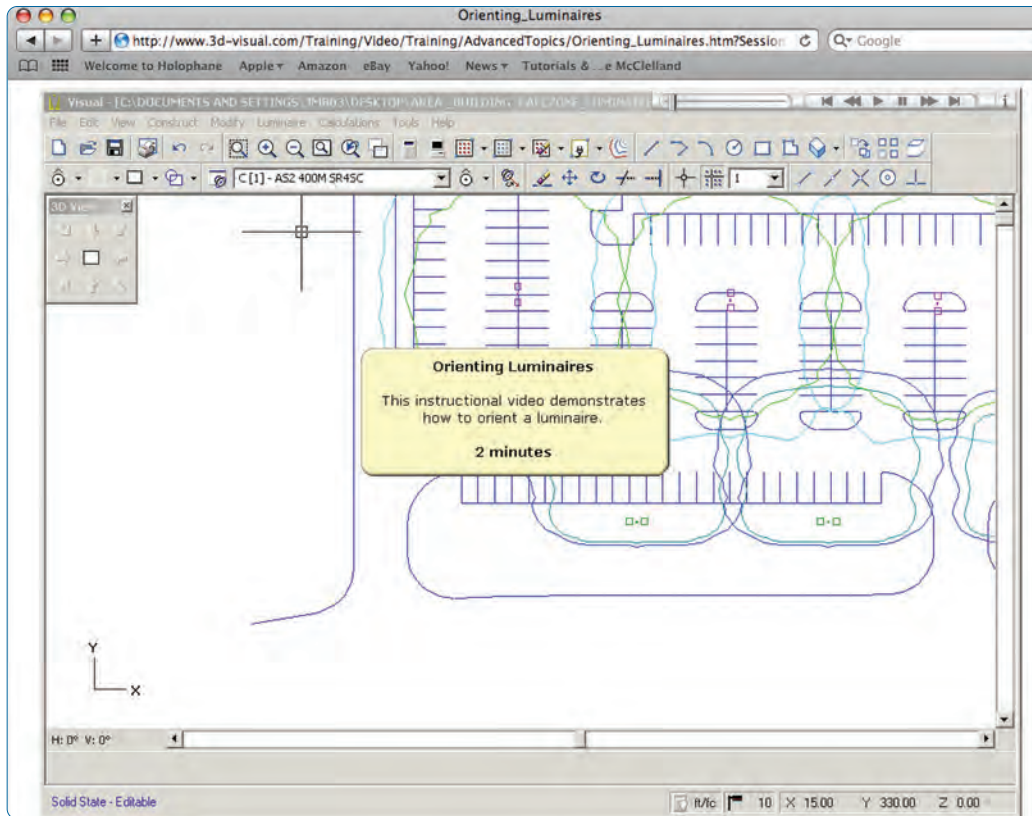

A unique approach has been taken with regard to the 3D interface to create a more intuitive and lighting-design-friendly manner of operation. As a result, working in 3D is easy, fast, and informative. It is a unique and powerful extension of your own design process. The Professional Edition will read files created using the Basic Edition. Flexible and intuitive, it enables you to analyze and modify lighting designs faster than ever before, empowering you to spend less time building projects, and more time designing.

True 3D Environment

- Visual provides the user with a true three-dimensional workspace, allowing the user to design and view lighting environments from any angle.
- It allows the user to work dynamically in any of the standard planes (X-Y, X-Z, or Y-Z). This makes building complex spaces easy and efficient.

Non-Orthogonal Surfaces

- Visual will model complex geometries accurately and in a time-efficient manner, including sloped ceilings, domes, and other curved surfaces.

Luminaire Schedules

- Visual allows an unlimited number of luminaire types.
- It provides a library of standard luminaire symbols and includes a symbol editor. Default information can be enhanced or changed as needed.

Flexible Calculation Grids

- Calculation grids can be added in any shape or orientation and on any surface desired.
- Masking of grids is accomplished either in blocks or individually. The points may be oriented in any direction.

Iso-Illuminance Curves

- Optional iso-illuminance curves for any luminaire or pole configuration assist in placement.

Obstructions

- Both interior and exterior designs may include obstructions of any shape, orientation or reflectance.
- Calculation grids are easily placed on any surface of an obstruction.
- There is no limit to the number of obstructions allowed.

Presentation Quality Results

- The results can be printed to any size media, from an 8.5" x 11" page to a full E-sized plotted page.
- The powerful print editor allows for completely customized pages, both in content and in appearance.

Additional Features

- Visual follows standard Windows and CAD interface protocols, making for a short learning curve.
- Both DXF and DWG format drawing files can be imported and exported.
- A Lumen Method tool is provided for the quick design and analysis of simple lighting layouts where uniform illuminance is the objective. The streamlined calculation engine computes even the most complicated designs in only a fraction of the time.

Educational opportunities

- Training videos on the visual-3d.com web site.
- Computer Lighting Calculations Seminars in Granville.

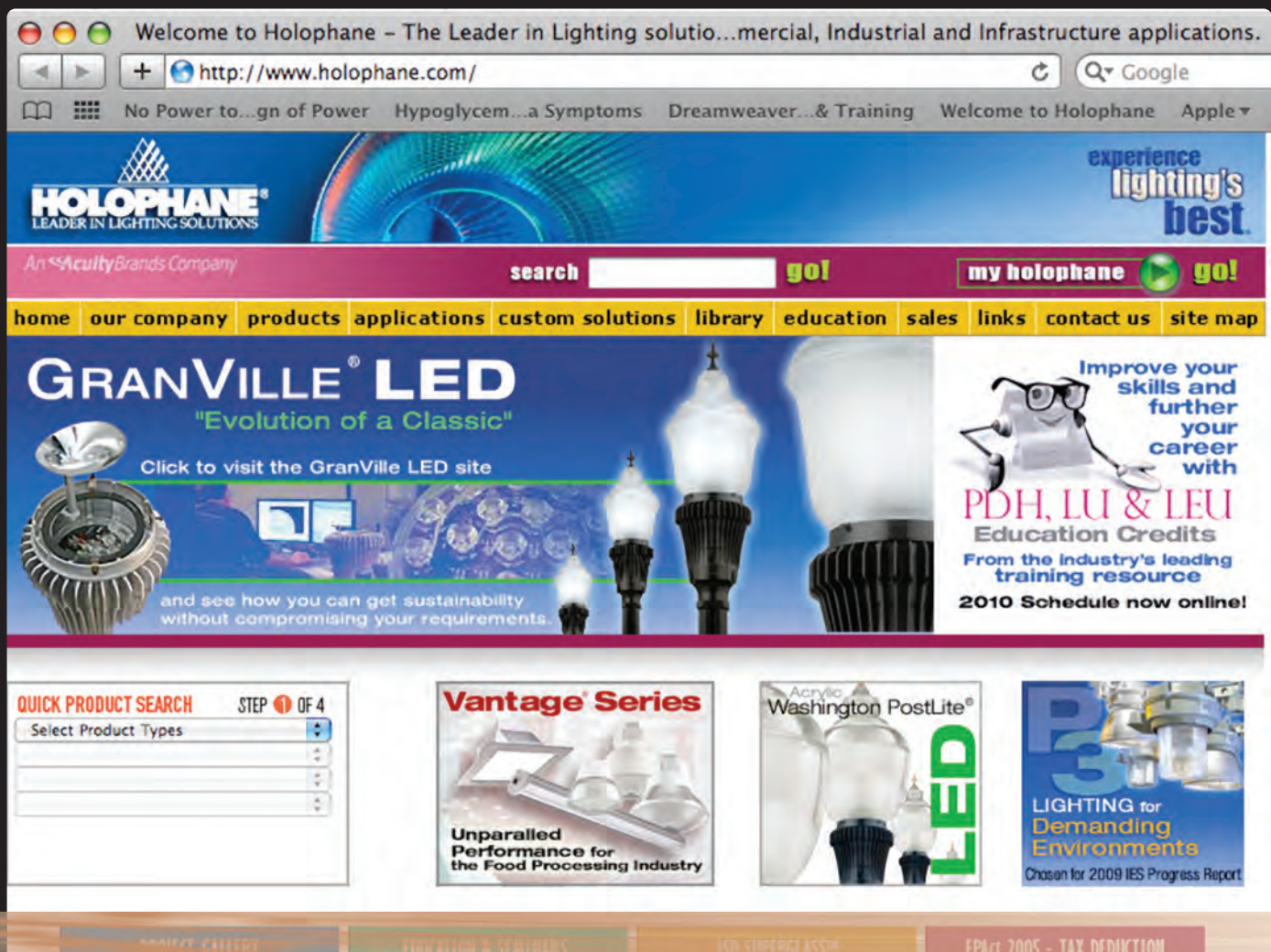

HOLOPHANE.COM RESOURCES

LIGHTING INFORMATION AT YOUR FINGERTIPS. HOLOPHANE.COM IS YOUR RESOURCE FOR EVERYTHING YOU NEED TO KNOW ABOUT THE LATEST PRODUCT INNOVATIONS, PRODUCT UPDATES, APPLICATIONS, TRAINING SEMINARS, AND HOLOPHANE NEWS. THE WEB SITE IS AN EASY TO USE, MOST CONVENIENT WAY TO GET THE MOST UP-TO-DATE INFORMATION YOU WANT, AND WHEN YOU NEED IT.



OPTI C	(D) DIA. (IN)	(P) HEIGHT (IN)	(G, N) HEIGHT T (IN)	(ER) HEIGHT SENSOR B	(A) HEIGHT SENSOR R
6611	18.00	23.25	27.00	32.00	26.00
6612	23.25	25.62	30.00	35.00	30.25

UP-TO-DATE PRODUCT INFORMATION

If you need any product information and you need it now, the best resource is the holophane.com web site. When you go the web page for a specific product you'll find the most current product information including; product photos, an overall general description, specification sheets, photometrics, brochures, and application information. If there's something you need to know and you can't find just click on the "Questions about this product" link and we'll get the answer to you as soon as we can.

NEW PRODUCT INNOVATIONS

The web site is an excellent source for new product innovations by Holophane. A web-based presentation is available outlining all of the innovative features a new product has to offer and how you can benefit from the revolutionary engineering that goes into a Holophane product that outlasts and outperforms.

MANY OTHER GREAT RESOURCES

There are many other great resources on the holophane.com web site, including a site map for a quick look at what is on the site. Here's a list of other web features you may be interested in:

- **Our Company** features an overview of Holophane and it's 100+ history in the lighting industry, latest corporate news and current career opportunities.
- **Applications.** Not sure exactly what Holophane product or family is right for your project? Simply use this page to browse our products based on specific market applications & examples.
- **Custom Solutions.** Unique needs require unique solutions. Let Holophane help you with all your custom lighting products... both indoor and outdoor.
- **Library.** Quick links to all publications in our library, including photometrics, specification sheets, lighting guides, case histories and many more.
- **Education.** The Light & Vision Center provides an educational opportunity for customers and fellow lighting professionals, as well as an intensive training facility for our factory direct sales representatives.
- **Sales.** A great source for contacting the sales rep near you.
- **Contact Us.** Can't find what you need? Fill out the General Inquiry form, and we'll have someone contact you.



HOLOPHANE[®]
LEADER IN LIGHTING SOLUTIONS

An **AcuityBrands** Company

Acuity Brands Lighting, Inc.

Holophane Headquarters, 3825 Columbus Road,
Granville, OH 43023

Holophane Canada, Inc. 9040 Leslie Street,
Suite 208, Richmond Hill, ON L4B 3M4

Holophane Europe Limited, Bond Ave.,
Milton Keynes MK1 1JG, England

Holophane, S.A. de C.V., Apartado Postal No. 986,
Naucalpan de Juarez, 53000 Edo. de Mexico

Contact your local Holophane factory sales representative for application assistance, and computer-aided design and cost studies. For information on other Holophane products and systems, call the Inside Sales Service Department at 866-759-1577. In Canada call 905-707-5830 or fax 905-707-5695.

Visit our web site at www.holophane.com



Buying products with the FSC label supports the growth of responsible forest management worldwide. The eco savings in the production of this brochure:

- 2 trees preserved for the future*
- 5 lbs waterborne waste not created*
- 42 gallons wastewater flow saved*
- 110 lbs solid waste not generated*
- 13 lbs net greenhouse gases prevented*
- 1,000,000 BTUs energy not consumed*